

TEST INFORMATION

TEST : PART TEST (PT)-1 (3 HOURS)

(Test Date : 15-04-2015)

Syllabus : Geometrical Optics, Electrostatics, Gravitation, Kinematics, Newton's laws of motion, Friction.

This DPP is to be discussed (17-04-2015)

PT-1 to be discussed (17-04-2015)

DPP No. # 03

Total Total Marks : 151

Max. Time : 116½ min.

Single choice Objective (–1 negative marking) Q. 1 to 15

(3 marks 2½ min.) [45, 37½]

Multiple choice objective (–1 negative marking) Q. 16 to 20

(4 marks, 3 min.) [20, 15]

Single Digit Subjective Questions (no negative marking) Q.21 to Q.27

(4 marks 2½ min.) [28, 17½]

Double Digits Subjective Questions (no negative marking) Q. 28 to 29

(4 marks 2½ min.) [8, 5]

Three Digits Subjective Questions (no negative marking) Q. 30 to 31

(4 marks 2½ min.) [8, 5]

Comprehension (–1 negative marking) Q.32 to 42

(3 marks 2½ min.) [33, 27½]

Match Listing (–1 negative marking) Q.43 to Q.45

(3 marks, 3 min.) [9, 9]

- Consider two infinite large parallel current carrying sheet. Current per unit width in both sheets is $\frac{1}{\sqrt{\pi}}$ A/m. If direction of current in both sheets is same than force per unit area on each sheet will be :
 (A) 10^{-7} N/m² (B) 0.5×10^{-7} N/m² (C) 2×10^{-7} N/m² (D) 10^{-5} N/m²
- Consider two uniformly charged concentric and coaxial rings of radii R and 2R. Total charge on inner ring is Q_1 and that on outer ring is Q_2 . Both rings are revolving in same sense with same angular velocity about its axis. If net magnetic induction at a distance R from the centre of the rings, on axis of rings is zero then $\frac{Q_1}{Q_2}$ is :
 (A) –1 (B) $-\frac{2\sqrt{2}}{5\sqrt{5}}$ (C) $-\frac{8\sqrt{2}}{5\sqrt{5}}$ (D) $-\frac{4\sqrt{2}}{3\sqrt{3}}$
- Conductor of length ℓ has shape of a semi cylinder of radius R ($\ll \ell$). Cross section of the conductor is shown in the figure. Thickness of the conductor is t ($\ll R$) and conductivity of its material varies with angle θ according to the law $\sigma = \sigma_0 \cos\theta$ where σ_0 is a constant. If a battery of emf ε is connected across its end faces (across the semi-circular cross-sections), the magnetic induction at the mid point O of the axis of the semi-cylinder is :

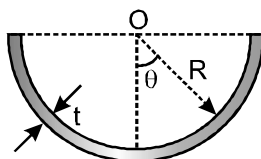

(A) $\frac{\mu_0 \sigma_0 \varepsilon t}{8\ell}$

(B) $\frac{\mu_0 \sigma_0 \varepsilon t}{4\ell}$

(C) $\frac{\mu_0 \sigma_0 \varepsilon t}{\ell}$

(D) $\frac{2\mu_0 \sigma_0 \varepsilon t}{\ell}$

4. In the shown circuit, all three capacitor are identical and have capacitance $C \mu\text{F}$ each. Each resistor has resistance of $R \Omega$. An ideal cell of emf V volts is connected as shown. Then the magnitude of potential difference across capacitor C_3 in steady state is :

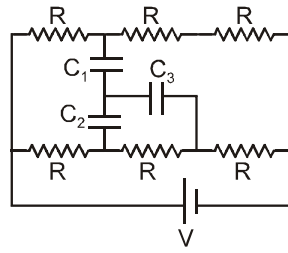

- (A) $\frac{V}{3}$ (B) $\frac{V}{2}$ (C) $\frac{2}{9}V$ (D) $\frac{3}{4}V$

5. Five bulbs B_1, B_2, B_3 and B_4 each of rating $60\text{W} / 200\text{V}$ and B_5 of rating $120\text{W} / 400\text{V}$ are connected as shown in circuit. Total power consumption by all the bulbs is :

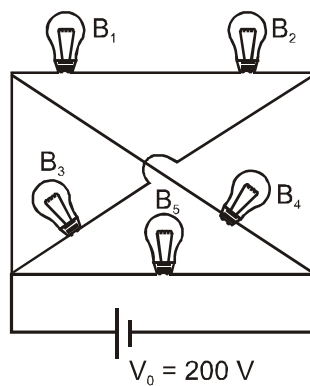

- (A) 240 W (B) 270 W (C) 90 W (D) 180 W

6. If an ideal cell of emf 5 volt shown in the figure gives a power of 10 W , find the powers consumed by the resistors 2Ω and 1Ω .

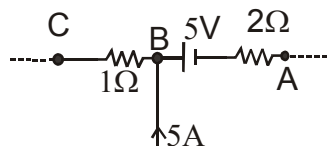

- (A) 2W, 18W (B) 8W, 49W (C) 8W, 18W (D) 2W, 49W

7. Four resistances are connected by an ideal battery of emf 50 volt, circuit is in steady state then the current in wire AB is :

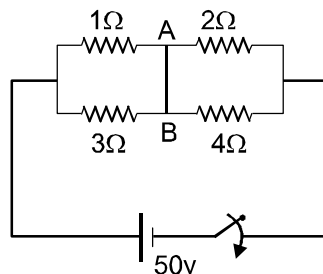

- (A) 1A (B) 2A (C) 3A (D) 4A

8. Three batteries are connected as shown in figure. Reading of ideal ammeters A_1 , A_2 & A_3 are :

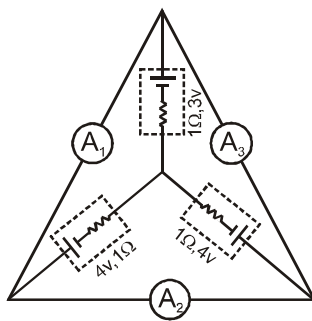

- (A) $\frac{1}{3}$ A, 0, $\frac{1}{3}$ A (B) 0.5 A, 0.5 A & 1A respectively
 (C) zero, 0.5 A & zero respectively (D) zero, zero & 1A respectively

9. The time when the voltage across the resistor drops to nearly 37% of the value just after the switch S_w is closed : ($R = 100 \text{ k}\Omega$, $C = 1\mu\text{F}$) is :

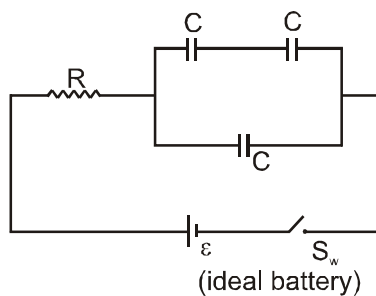

- (A) 0.15 s (B) 0.30 s (C) 0.45 s (D) 0.60 s

10. AB is potentiometer wire of resistance per unit length $0.09 \Omega/\text{cm}$ and ϵ is an unknown emf of a battery to be measured. ϵ cannot be measured using the potentiometer shown if the value of ϵ is (select the most appropriate answer)

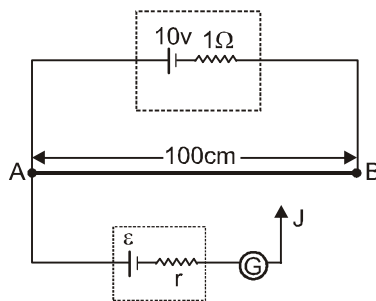

- (A) greater than 8.0 V (B) greater than 8.5 V
 (C) greater than 9.0 V (D) greater than 9.5 V

11. In the circuit diagram a capacitor which is initially uncharged is connected to an ideal cell of emf ε through a resistor 'R'. A leaky dielectric fills the space between the plates of dielectric. The capacitance of the capacitor with dielectric is C. Resistance of the dielectric is $R' = R$.

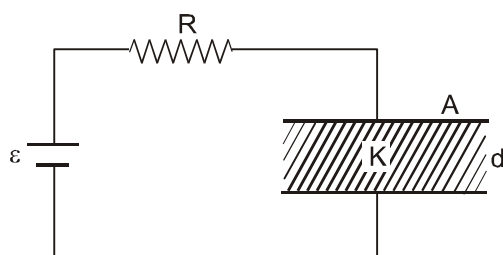

- (A) Charge on the capacitor as function of time t is $\frac{\varepsilon C}{2} \left[1 - e^{-\frac{2t}{RC}} \right]$
- (B) Maximum charge on the capacitor is $\frac{\varepsilon C}{2}$.
- (C) When charge on the capacitor is maximum, then current in the circuit is $\frac{\varepsilon}{2R}$
- (D) All of the above options are true

12. Charge flown through the battery after closing the switch is (initially all capacitors are uncharged) :

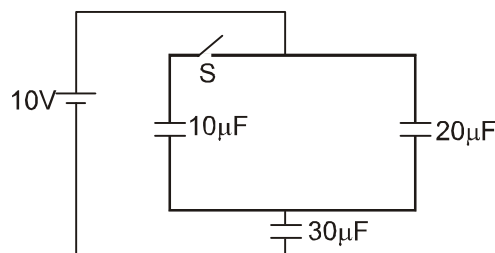

- (A) 20mC (B) 30mC (C) 120mC (D) 150mC
13. Electric current through 400Ω resistor is :

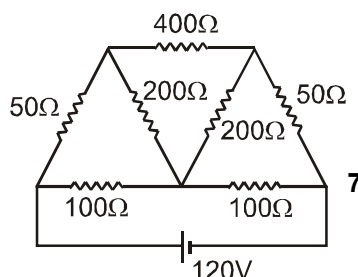

- (A) 0.8 A (B) 0.6 A (C) 0.4 (D) 0.2 A
14. Two coaxial long solenoids of equal lengths have current, i_1, i_2 , number of turns per unit length n_1, n_2 and radius r_1, r_2 respectively. If $n_1 i_1 = n_2 i_2$ and the two solenoids carry current in opposite sense, the magnetic energy stored per unit length is [$r_2 > r_1$]
- (A) $\frac{\mu_0}{2} n_1^2 i_1^2 \pi (r_2^2 - r_1^2)$ (B) $\mu_0 n_1^2 i_1^2 \pi (r_2^2 - r_1^2)$ (C) $\frac{\mu_0}{2} n_1^2 i_1^2 \pi r_1^2$ (D) $\frac{\mu_0}{2} n_2^2 i_2^2 \pi r_2^2$

15. Two cells of emf ε_1 and ε_2 ($\varepsilon_2 < \varepsilon_1$) are joined as shown in figure :

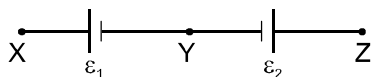

When a potentiometer is connected between X and Y it balances for 300 cm length against ε_1 . On connecting the same potentiometer between X and Z it balances for 100 cm length against ε_1 and ε_2 . Then the ratio $\frac{\varepsilon_2}{\varepsilon_1}$ is :

- (A) $\frac{1}{3}$ (B) $\frac{3}{4}$ (C) $\frac{1}{4}$ (D) $\frac{2}{3}$

16. In the figure shown capacitors A and B of capacitance C are in steady state. A dielectric slab of dielectric constant $K = 2$ and dimensions equal to the inner dimensions of the capacitor is inserted in the space between the plates of the capacitor B. In steady state choose the correct options

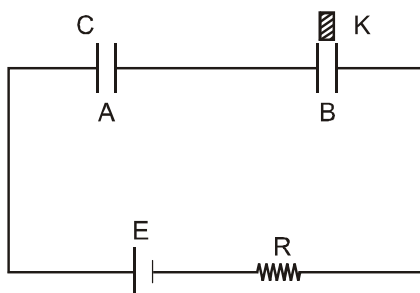

- (A) Charge on each capacitor will increase by $\frac{CE}{6}$.
- (B) In the process of inserting the dielectric, energy of the battery decreases by an amount of $\frac{CE^2}{6}$.
- (C) In the process of inserting the dielectric, energy of the battery increases by an amount of $\frac{CE^2}{6}$.
- (D) In the process of inserting the dielectric, energy in the capacitor A increases by an amount of $\frac{7CE^2}{72}$.

17. Three large identical conducting plates of area A are closely placed parallel to each other as shown (the area A is perpendicular to plane of diagram). The net charge on left, middle and right plates are Q_L , Q_M and Q_R respectively. Three infinitely large parallel surfaces S_L , S_M and S_R are drawn passing through middle of each plate such that surfaces are perpendicular to plane of diagram as shown. Then pick up the correct option(s).

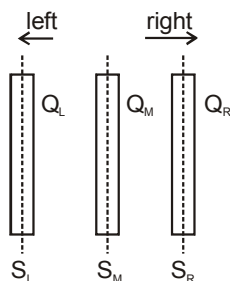

- (A) The net charge on left side of surface S_L is equal to net charge on right side of surface S_R .
- (B) The net charge on left side of surface S_L is equal to net charge on right side of surface S_M .
- (C) The net charge on left side of surface S_L is equal to net charge on right side of surface S_L .
- (D) The net charge on right side of surface S_L is equal to net charge on left side of surface S_R .

18. A single circular loop of wire with radius 0.02 m carries a current of 8.0 A. It is placed at the centre of a solenoid that has length 0.65 m, radius 0.080 m and 1300 turns.

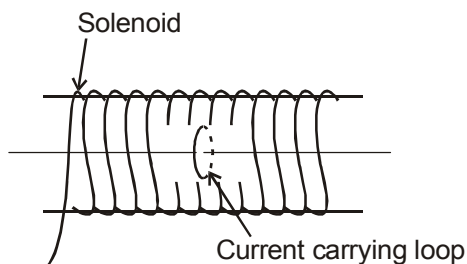

- (A) The value of the current in the solenoid so that the magnetic field at the centre of the loop becomes zero, is equal to 44 mA.
 (B) The value of the current in the solenoid so that the magnetic field at the centre of the loop becomes zero, is equal to 100 mA.
 (C) The magnitude of the total magnetic field at the centre of the loop (due to both the loop and the solenoid) if the current in the loop is reversed in direction from that needed to make the total field equal to zero tesla, is $8\pi \times 10^{-5}$ T.
 (D) The magnitude of the total magnetic field at the centre of the loop (due to both the loop and the solenoid) if the current in the loop is reversed in direction from that needed to make the total field equal to zero tesla, is $16\pi \times 10^{-5}$ T.
19. In the circuit shown in figure, E_1 and E_2 are two ideal sources of unknown emfs. Some currents are shown. Potential difference appearing across 6Ω resistance is $V_A - V_B = 10$ V. Choose correct options.

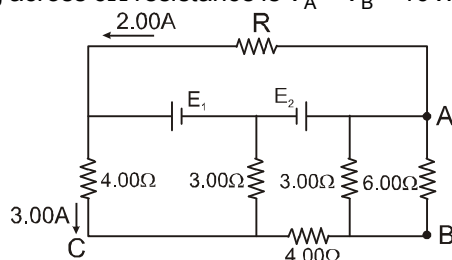

- (A) The current in the 4.00Ω resistance between C & B is 5A.
 (B) The unknown emf E_1 is 36 V.
 (C) The unknown emf E_2 is 54 V.
 (D) The resistance R is equal to 9Ω .
20. In the figure shown

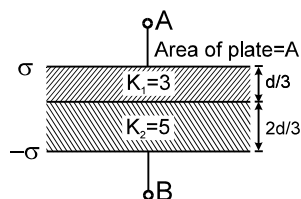

- (A) the ratio of energy density in 1st dielectric to second dielectric is $\frac{5}{3}$
 (B) the ratio of energy density in 1st dielectric to second dielectric is $\frac{1}{1}$
 (C) total induced surface charge on the interface of the two dielectric is $\frac{2\sigma}{15}$
 (D) total induced surface charge on the interface of the two dielectric is $-\frac{2\sigma}{15}$

21. In the circuit shown, current through the resistance 2Ω is i_1 and current through the resistance 30Ω is i_2 . Find the ratio $\frac{i_1}{i_2}$.

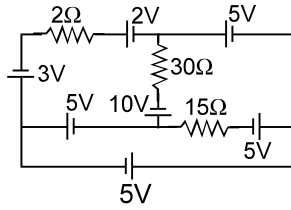

22. Find the value of R (in Ω) so that there is no current through 5V cell. All the cells & ammeters are ideal in the circuit shown.

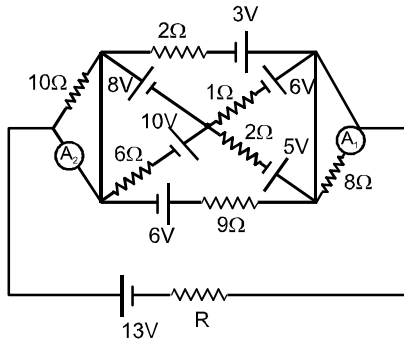

23. Find the potential difference (in volt) between the points A and B of the circuit shown in figure.

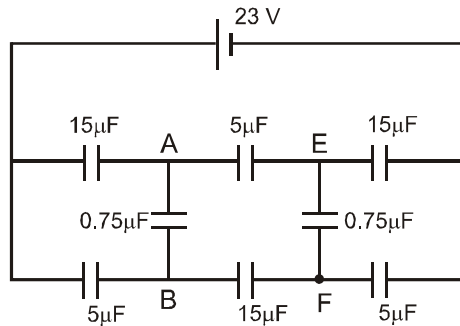

24. In the given circuit if the internal resistance of the batteries are negligible, then for what value of resistance R (in Ω) will the thermal power generated in it be maximum.

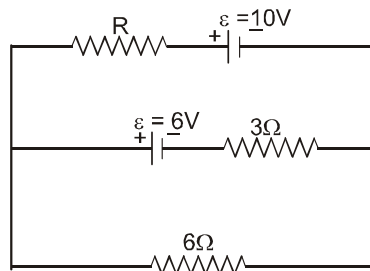

25. A long straight wire is carrying current $I_1 = 2/5$ A in +z direction. The x - y plane contains a closed circular loop carrying current $I_2 = 5/2$ A and not encircling the straight wire, then the force (in newton) on the loop will be ? (radius of the circular loop $R = 3/4$ m).

26. Magnetic field is uniform and has a magnitude B in the interior of a very long solenoid far from its ends. One of the ends of the solenoid is closed with a thin flat plastic cover. A single small electrical loop of radius R lies on the cover so that its center is on the axis of the solenoid. The electrical current flowing in the loop is I . If the mechanical tension in the loop's wire is $\frac{BIR}{x}$, then value of x :

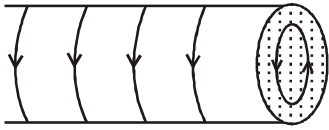

27. Figure shows circular region of radius $R = \sqrt{3}$ m in which upper half has uniform magnetic field $\vec{B} = 0.2(-\hat{k})$ T and lower half has uniform magnetic field $\vec{B} = 0.2\hat{k}$ T. A very thin parallel beam of point charges each having mass $m = 2$ gm, speed $v = 0.3$ m/sec and charge $q = +1$ mC are projected along the diameter as shown in figure. A screen is placed perpendicular to initial velocity of charges as shown. If the distance between the point on screen where charges will strike is $4X$ meters, then calculate X .

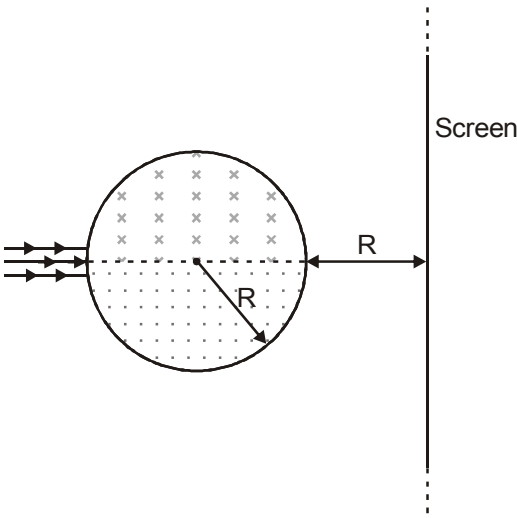

28. Internal resistance of a cell is $r = 5\Omega$ & is connected in potentiometer (wire length = 1m) circuit arrangement as shown in figure, which shows two circular conducting rings R_1 & R_2 each having radii 20 cm cross each other at conducting joints A & B. Section AB subtends 120° at the center of each ring. Resistance per unit length of R_1 & R_2 are $\frac{3}{\pi}\Omega/\text{cm}$ & $\frac{6}{\pi}\Omega/\text{cm}$ respectively. Cell is connected across points C & D of rings lying on perpendicular bisector of AB. Now when switch Sw remains closed, balancing length at null point is 48 cm. Find the balancing length (in cm.) when switch Sw is opened.

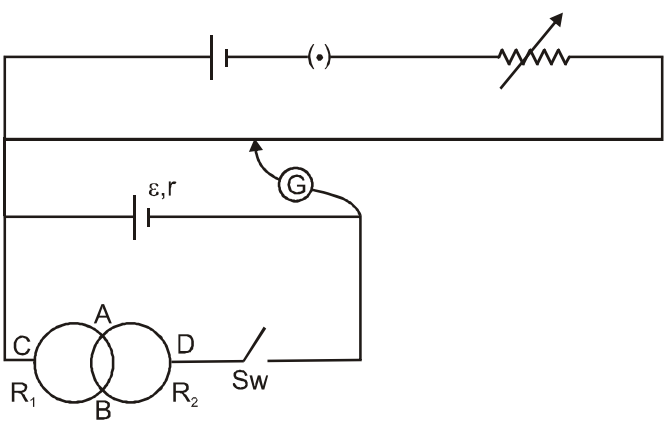

29. Find the sum of magnitude of current (in Amp.) through R_1 , R_2 and R_3 . All cells are ideal

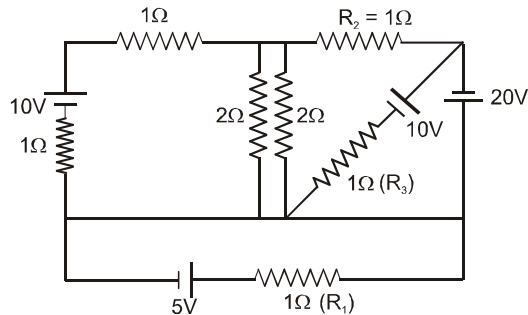

30. A parallel plate capacitor is to be designed which is to be connected across 1 kV potential difference. The dielectric material which is to be filled between the plates has dielectric constant $K = 6\pi$ and dielectric strength 10^7 V/m. For safety the electric field should never exceed 10% of the dielectric strength. With such specifications, if we want a capacitor of capacitance 50 pF, what minimum area (in mm^2) of plates is required for safe working?

(use $\epsilon_0 = \frac{1}{36\pi} \times 10^{-9}$ in MKS)

31. A loop PQR formed by three identical uniform conducting rods each of length $a = 20$ cm is suspended from one of its vertices (P) so that it can rotate about horizontal fixed smooth axis CD. Initially plane of loop is in vertical plane. A constant current $i = 10$ A is flowing in the loop. Total mass of the loop is $m = 60$ gm. At $t = 0$, a uniform magnetic field of strength B directed vertically upwards is switched on. Find the minimum value of B in mT so that the plane of the loop becomes horizontal (even for an instant) during its subsequent motion.

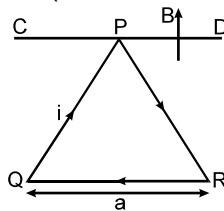

COMPREHENSION - 1

A conducting wire is bend into a loop as shown in the figure. The segment AOB is parabolic given by the equation $y^2 = 2x$, while segment BA is a straight line $x = 2$.

The magnetic field in the region $\vec{B} = -8\hat{k}$ tesla and the current in wire is 2A.

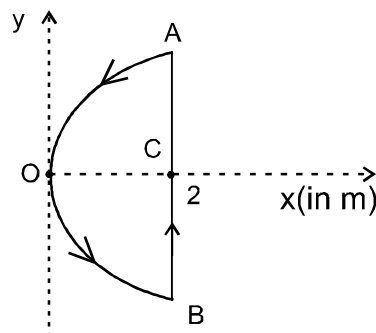

32. The torque on the loop will be :
 (A) $16\sqrt{2}\text{N} - \text{m}$ (B) $16\text{N} - \text{m}$ (C) $18\sqrt{2}\text{N} - \text{m}$ (D) zero

33. The magnetic field created by the current in the loop at point C will be
 (A) $-\frac{\mu_0}{4\pi} \hat{k}$ (B) $-\frac{\mu_0}{8\pi} \hat{k}$ (C) $-\frac{\mu_0 \sqrt{2}}{\pi} \hat{k}$ (D) none
34. If the loop were rotated about the z-axis with an angular speed of 1rad/sec. Then magnitude of emf induced across the straight segment AC will be
 (A) 32V (B) 8V (C) 16V (D) 4V

COMPREHENSION - 2

The figure shown is part of the circuit at steady state.

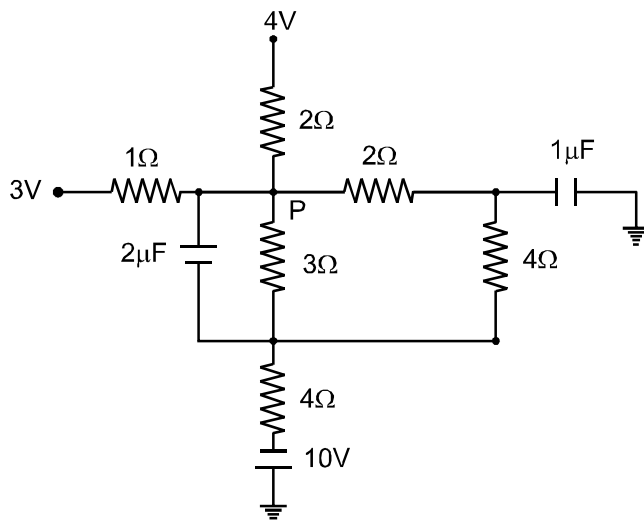

35. The potential of point P is :
 (A) 1V (B) 2V (C) 3V (D) 4V
36. The charge on $2\mu\text{F}$ capacitor is :
 (A) $2\mu\text{C}$ (B) $4\mu\text{C}$ (C) $6\mu\text{C}$ (D) $8\mu\text{C}$
37. The current flowing from 3Ω resistor is :
 (A) 2 A (B) $\frac{4}{3}$ A (C) $\frac{2}{3}$ C (D) None of these

COMPREHENSION - 3

A galvanometer measures current which passes through it. A galvanometer can measure typically current of order of mA. To be able to measure currents of the order of amperes of main current, a shunt resistance 'S' is connected in parallel with the galvanometer.

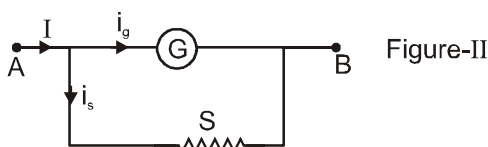

38. The resistance of the shunt 'S' and resistance 'G' of the galvanometer should have the following relation.
 (A) $S = G$ (B) $S \gg G$ (C) $S \ll G$ (D) $S < G$

39. If resistance of galvanometer is 10Ω and maximum current i_g is 10mA then the shunt resistance required so that the main current 'I' can be upto 1A is (in Ω)
- (A) $\frac{99}{10}$ (B) $\frac{10}{99}$ (C) 990 (D) $\frac{99}{1000}$

COMPREHENSION - 4

Three identical metal plates of area S are at equal distances b as shown. Initially metal plate A is uncharged, while metal plates B and C have respective charges $+Q_0$ and $-Q_0$ initially as shown. Metal plates A and C are connected by switch K through a resistor of resistance R . The key K is closed at time $t = 0$

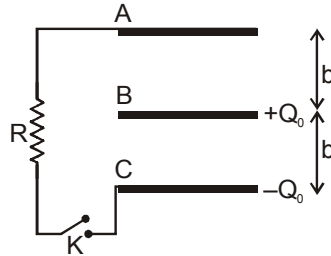

40. Then the magnitude of current in amperes through the resistor at any later time t is :
- (A) $\frac{Q_0 b}{RS\epsilon_0} e^{-\frac{bt}{RS\epsilon_0}}$ (B) $\frac{Q_0 b}{RS\epsilon_0} e^{-\frac{2bt}{RS\epsilon_0}}$ (C) $\frac{Q_0 b}{2RS\epsilon_0} e^{-\frac{2bt}{RS\epsilon_0}}$ (D) $\frac{Q_0 b}{2RS\epsilon_0} e^{-\frac{bt}{RS\epsilon_0}}$
41. After the steady state is achieved, the charge on plate A is :
- (A) $\frac{Q_0}{2}$ (B) $-\frac{Q_0}{2}$ (C) $\frac{Q_0}{3}$ (D) $-\frac{Q_0}{3}$
42. The total heat produced dissipated by resistor of resistance R is :
- (A) $\frac{Q_0^2 b}{4S\epsilon_0}$ (B) $\frac{Q_0^2 b}{8S\epsilon_0}$ (C) $\frac{Q_0^2 b}{2S\epsilon_0}$ (D) $\frac{3Q_0^2 b}{4S\epsilon_0}$
43. Column I gives certain situations in which capacitance of a capacitor is changed by different means. Column II gives resulting effect under different conditions. Match the proper entries from column-2 to column-1 using the codes given below the columns,

Column I

- (P) The plates of a plane parallel capacitor are slowly pulled apart. Then the magnitude of electric field intensity inside the capacitor.
- (Q) The plates of a plane parallel plate capacitor are slowly pulled apart. Then the potential energy stored in the capacitor.
- (R) The capacitance of an air filled plane parallel plate capacitor on insertion of dielectric
- (S) A dielectric slab is inserted inside an air filled plane parallel plate capacitor. The potential energy stored in the capacitor.

Column II

- (1) Increases if the capacitor is maintained at constant charge.
- (2) Decreases if the capacitor is maintained at constant charge
- (3) Increases if the capacitor is maintained at constant potential difference.
- (4) Decreases if the capacitor is maintained at constant potential difference.

- | | | | | |
|-----|-----|-----|-----|-----|
| | (P) | (Q) | (R) | (S) |
| (A) | 1 | 2 | 4 | 3 |
| (B) | 4 | 1 | 3 | 2 |
| (C) | 1 | 2 | 3 | 4 |
| (D) | 4 | 1 | 2 | 3 |

44. A circuit involving five ideal cells, three resistors (R_1 , R_2 and 20Ω) and a capacitor of capacitance $C = 1\mu\text{F}$ is shown. At steady state match the proper entries from column-2 to column-1 using the codes given below the columns,

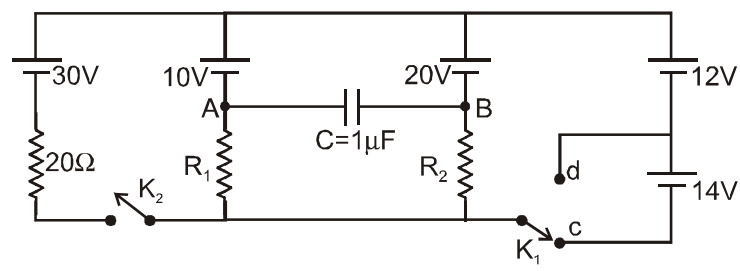

Column-I

- (P) K_2 is open and K_1 is in position C
 (Q) K_2 is open and K_1 is in position D
 (R) K_2 is closed and K_1 is in position C
 (S) K_2 is closed and K_1 is in position D

Column-II

- (1) Potential at point A is greater than potential at B
 (2) Current through R_1 is downward
 (3) Current through R_2 is upward
 (4) Charge on capacitor is $10\mu\text{C}$.

	(P)	(Q)	(R)	(S)
(A)	4	3	1	2
(B)	3	1	4	2
(C)	3	2	1	4
(D)	1	4	3	2

45. Column I lists the field in a region and Column II lists the path of a charge q and mass m on which the particle can move. Match the proper entries from column-2 to column-1 using the codes given below the columns, [Consider all fields to be uniform]

Column I

- (P) Only electric field \vec{E} is present
 (Q) Only magnetic field \vec{B} is present
 (R) Only gravitational field \vec{g} is present
 (S) Both electric field \vec{E} and magnetic field \vec{B} are present

Column II

- (1) The particle can move on a straight line
 (2) The particle can move on a circle
 (3) The particle can move on parabolic path
 (4) The particle can remain in rest

	(P)	(Q)	(R)	(S)
(A)	4	3	1	2
(B)	3	1	4	2
(C)	3	2	1	4
(D)	1	2	3	1

ANSWER KEY OF DPP No. # 02

1. (A)	2. (C)	3. (D)	4. (A)	5. (B)	6. (B)	7. (B)
8. (D)	9. (A)	10. (B)	11. (B)	12. (D)	13. (C)	14. (C)
15. (C)	16. (B)	17. (C)	18. (A,C,D)	19. (A,B,D)	20. (C,D)	
21. (B,D)	22. (A,D)	23. (B,C,D)	24. (A,B,C)	25. 6	26. $\alpha = 4$	
27. 10 sec	28. 125	29. 3	30. 5	31. 3	32. (C)	33. (D)
34. (A)	35. (D)	36. (A)	37. (B)	38. (A)	39. (D)	
40. (A) – p,s ; (B) – p,t ; (C) – q,s ; (D) – q, s		41. (B)	42. (A)			